



*TELLER***SCAN**[®] TS240



TellerScan[®] TS240 User Manual

December 2013_Rev 122013

Table of Contents

About the TellerScan TS240	4
Radio Frequency Interference	4
TellerScan TS240 System Requirements	4
TellerScan TS240 Included Equipment	5
External View of the TellerScan TS240	6
Rear View of the TellerScan TS240	6
TellerScan TS240 Initial Setup	7
New User Notice	7
Cable Connections and Scanner Placement	7
Installing the 1 Line Printer Ink Cartridge	8
Installing the 1 Line Printer Ink Cartridge (continued)	9
Installing the 4 Line Printer Ink Cartridge	10
Installing the Ink Cartridge (continued)	11
Installing the Franker Roller	12
Testing the Scanner	13
Installing the Optional USB Driver	13
Installing ScanLite2	13
LED Status Indicator	14
LED Status Indicator	14
LED Status Indicator (continued)	15
Loading Items into the Scanner	16
Accessing the TellerScan TS240	17
Accessing the Internal Document Path	17
Accessing the Cameras	17
Accessing the Cameras (continued)	18
Closing the Camera Door	18
TellerScan TS240 Routine Maintenance	19
TellerScan TS240 Maintenance Overview	19
Inspect the TS240 Document Track	19
Cleaning the TS240 Camera	19
Cleaning the TS240 Drive Rollers Using a Cleaning Card	20
Cleaning the TS240 Drive Rollers Using a Cleaning Swab	21
Replacing the SADR Discrimination Roller	22

TellerScan TS240 Troubleshooting	23
Document Feeding Problems	23
Clearing Jams	23
Image Quality	23
MICR Errors	23
Using the Diagnostic Pop Up	23
TellerScan TS240 Frequently Asked Questions	24
Is Using a Check Jogger Recommended?	24
What is the Typical Cleaning Interval?	24
What is the LED Status Light Sequence?	24
What About Avoiding MICR Read Head Interference?	24
How Long Does the Ink Cartridge Last?	24
What is the Entry Tray Capacity?	24
What is the Exit Pocket(s) Capacity?	24
How Many Checks Per Minute Should My TS240 Scan?	24
TellerScan TS240 Specifications	25
Digital Check Contact Information	26

About the TellerScan TS240

The TellerScan TS240 is an easy-to-use, high volume check scanner that automatically scans the front and/or back side of checks and reads the MICR (Magnetic Ink Character Recognition) code line. The images and data are then transmitted through a USB (Universal Serial Bus) interface to the PC. The TS240 has an auto feeder that handles up to 100 items and a 100 item exit pocket.

The TS240 is rated at up to 100 documents per minute (DPM) scanning speed. Speeds will vary based on the length of the document, applications used, the PC processing speeds and specific scanner model.

The TS240 does not have an 'On / Off Switch', but will become fully activated when the USB cable is connected to a powered on PC. The TS240 is automatically powered off when the PC powers down as it senses the loss of power to the USB port.

Radio Frequency Interference

The TS240 could generate or use radiate radio frequency energy. If the unit is not installed and used properly, that is, in strict accordance with the instructions in this manual it could cause harmful interference to radio communications. It has been tested and found to comply with the limits for Class B digital devices pursuant to Subpart J of Part 15 of FCC Rules, which are designed to provide reasonable protection against harmful interference when operated in a commercial environment.

Operation of this equipment in a residential area is not likely to cause interference due to its Class B rating.

TellerScan TS240 System Requirements

Recommended	Minimum
2.4 GHz Dual Core Processor or faster 2 GB RAM or more	1.6 GHz Pentium IV class processor or faster 1 GB RAM
10 GB free disk space	1.5 GB free disk space
Windows 7 or 8 (64 bit)	Windows XP, Windows Vista, Windows 7 or 8
USB 2.0 port	USB 2.0 port
DCC API 12.05 or newer	DCC API 11.02 for Energy Star models DCC API 10.05 for standard models

TellerScan TS240 Included Equipment

The TellerScan TS240 includes the following equipment in the box:

- ✓ TellerScan TS240 check scanner



- ✓ 100v-240v 50/60hz voltage sensing, external power supply and cord



- ✓ USB 2.0 cable



- ✓ Ink cartridge - MS0083 (1 line printer) or MS0095 (4 line printer) depending on model
Note: Ink cartridges are included only with 'Inkjet' models



- ✓ Franker stamp
Note: Ink cartridges are included only with 'Franker' models

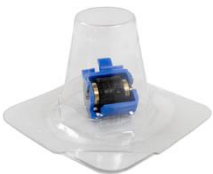

TellerScan TS240 Features

External View of the TellerScan TS240

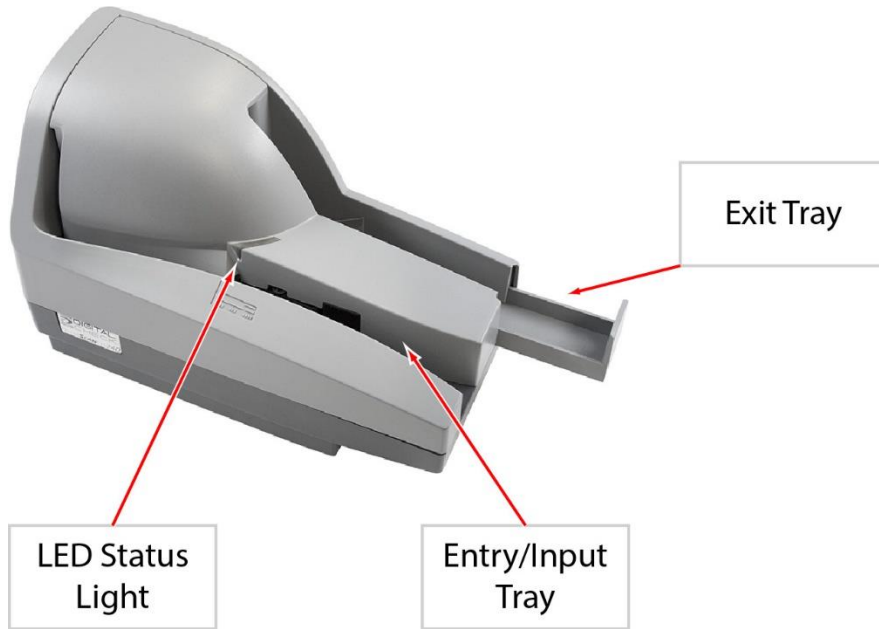

Rear View of the TellerScan TS240

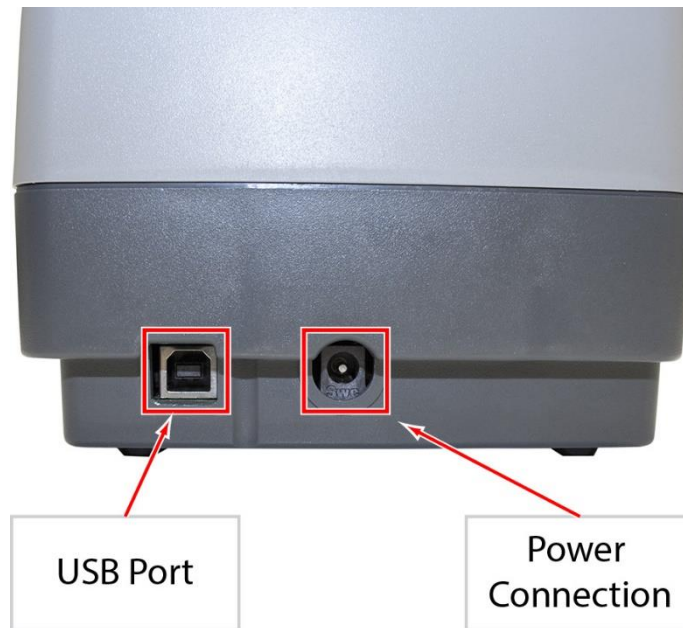

TellerScan TS240 Initial Setup

New User Notice

PLEASE NOTE: Do not connect the 'USB' cable from the scanner to your PC before installing the 'drivers' or the 'scanning application / software'. Digital Check does not provide scanning software. Please contact your bank or other solution provider for further assistance with installing the driver or getting the scanning software set up or installed.

Digital Check provides only an optional driver installation utility and a separate demonstration program. See the 'Installing the Optional USB Driver' section or the 'Installing Scanlite2' section for additional information.

Cable Connections and Scanner Placement

Note: Do not connect the 'USB' cable from the scanner to your PC before installing the 'drivers' or the 'scanning application / software'.

- ✓ Place the unit on a flat surface near the PC and away from direct light sources such as spot lights or desk lamps. Place the scanner in a position that is at least 6 inches away from any power supply, other electronic devices, pneumatic tubes at the teller window, etc.
- ✓ Connect the 'Power Cord' for the external 'Power Supply' to the 'Power Supply' and then plug the connector into the rear 'Power Connection' port.
- ✓ Connect the 'USB' cable by plugging it into the rear USB port.

Installing the 1 Line Printer Ink Cartridge

Note: This step only applies to TellerScan TS240s that have the optional inkjet configuration. Follow these instructions when installing the ink cartridge for the first time, or when replacing an empty cartridge.

Inkjet platform style might vary based on production. The cartridges are installed the same way for all TS240 1 line platform styles.

Step 1: Lift up on the 'Center Cover' to remove it and provide access to the 'Ink Cartridge Platform'.



Remove
Center Cover

Center
Cover



Inkjet
Platform

Step 2: Open the ink cartridge pouch and remove the protective tape covering the ink nozzles. Be careful not to touch the ink nozzle with your fingers or allow it to come in contact with anything else.



Remove
Tape Seal

Installing the 1 Line Printer Ink Cartridge (continued)

Step 3: Insert the nozzle end of the cartridge into the platform while keeping the end of the cartridge tilted slightly upward. Push down on the rear of the cartridge until it clicks twice and snaps into position.



Insert the Ink Cartridge at a slight angle

Nozzle end slight angle



Push down on the cartridge to fully seat

Correctly Inserted

Step 4: Verify that the cartridge is properly installed. The cartridge should appear tilted at a slight angle when fully seated. Replace the 'Center Cover' by setting it back on the unit vertically.

Note: If the scanner has to be transported by common carrier from one place to another or will experience extended periods of inactivity, it is advisable to remove the ink cartridge from the scanner and seal it in an airtight bag. If the cartridge has not been used for an extended period of time, it might be necessary to clean the inkjet nozzles by gently blotting them with a towel dampened with water or using Digital Checks Inkjet Cleaning Swabs (PN: IS0032 – available at www.digitalcheck.com).

Installing the 4 Line Printer Ink Cartridge

Follow these instructions when installing the ink cartridge for the first time, or when replacing an empty cartridge.

Note: The following steps must be followed when installing a new cartridge, replacing a cartridge or prior to troubleshooting any application related inkjet errors.

- 1.) Cartridge must be at room temperature (65-80 degrees) before being installed
- 2.) Insert the 4 line print cartridge
- 3.) Wait 10 seconds (the cartridge will perform a self-check during this period)
- 4.) The scanner is now ready to be used

Step 1: Lift up on the 'Center Cover' to remove it and provide access to the 'Ink Cartridge Platform'.



Step 2: Open the ink cartridge pouch and remove the protective tape covering the ink nozzles. Be careful not to touch the ink nozzle with your fingers or allow it to come in contact with anything else.



Remove
Tape Seal

Installing the Ink Cartridge (continued)

Step 3: Press on the 'Push to Open' blue tab on the side of the inkjet platform to open the latch.

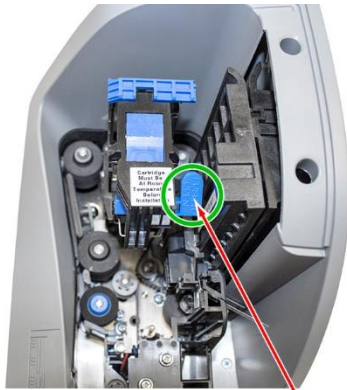

Press the
Push to Open
tab

Blue Push
to Open tab

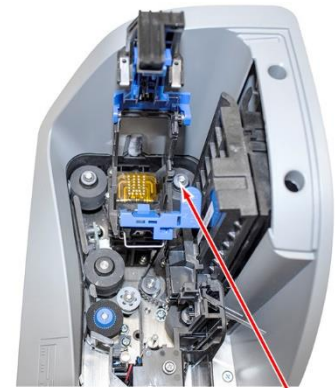

Latch Opened

Step 4: Carefully insert the cartridge into the platform from the top with the contacts facing down. Make sure that the cartridge is fully seated by pressing on the top of the cartridge.

Step 5: Close and secure the top latch. Press down on the 'Push to Close' section of the latch. Replace the 'Center Cover' by setting it back on the unit vertically.

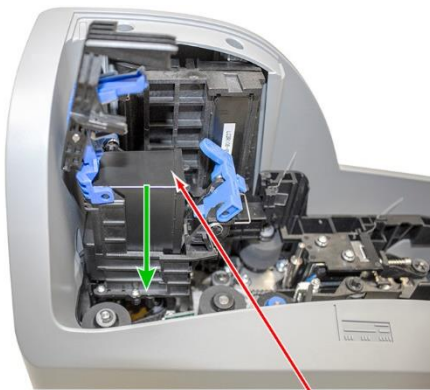

Insert Cartridge
with print contacts
facing down

Upright and
installed



Push down on
the section marked
Push to Close

Push to
Close section

Note: If the scanner has to be transported by common carrier from one place to another or will experience extended periods of inactivity, it is advisable to remove the ink cartridge from the scanner and seal it in an airtight bag. If the cartridge has not been used for an extended period of time, it might be necessary to clean the inkjet nozzles by gently blotting them with a towel dampened with water or using Digital Checks Inkjet Cleaning Swabs (PN: IS0032 – available at www.digitalcheck.com).

Installing the Franker Roller

Note: This step only applies to TellerScan TS240s that have the optional franker configuration. Follow these instructions when installing the franker roller for the first time, or when replacing an empty franking roller.

Step 1: Remove the Center and Outer scanner covers. Locate and remove the White Nylon Thumbscrew.

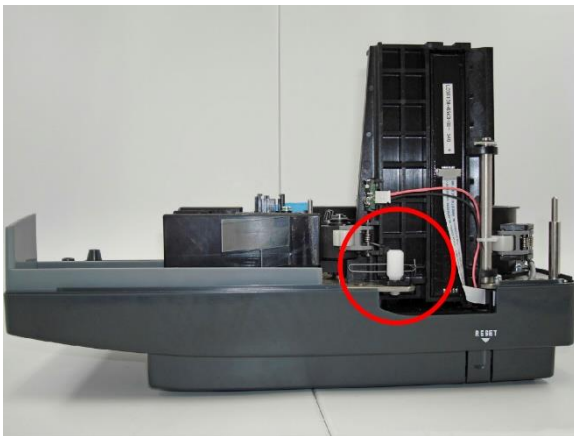

Step 2: Swing out the outer Camera Door. Locate the Franker Roller Mounting Post.

Hold the Franker Roller with the tab facing out and lined up with the Metal Spring. Snap the Franker Roller onto the Mounting Post.

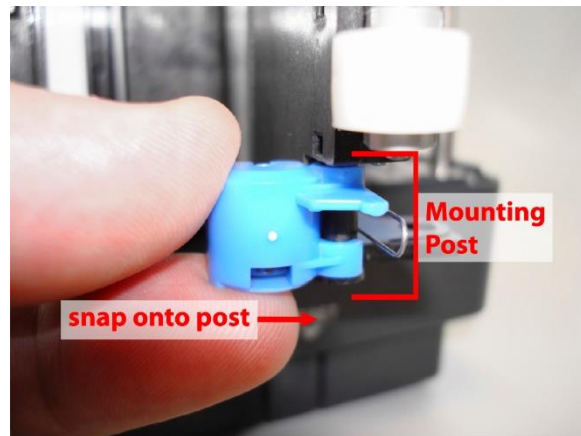

Step 3: Rotate the Franker Roller until it touches the Metal Spring (as shown).

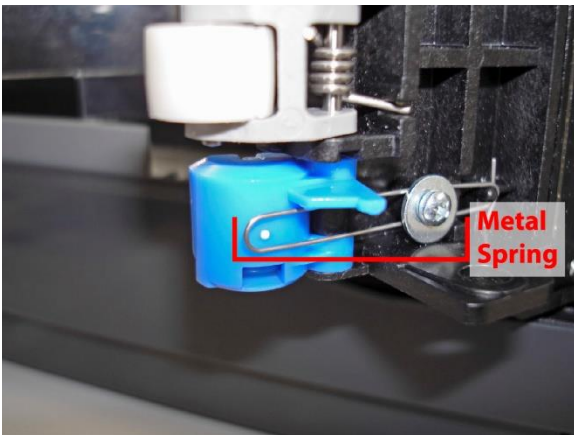

Step 4: Close the Camera Door and screw the White Nylon Thumbscrew back in place.

Replace the Center and Outer scanner covers.

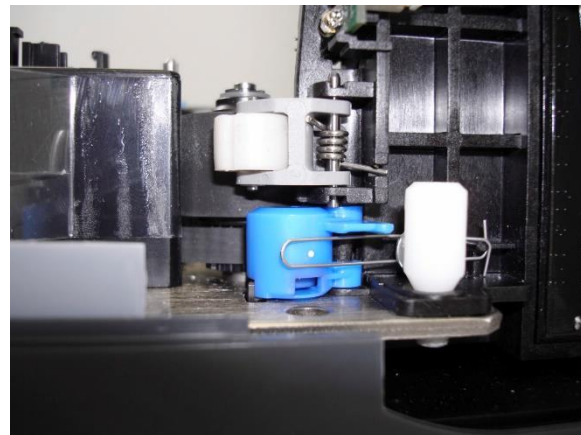

Testing the Scanner

Installing the Optional USB Driver

PLEASE NOTE: Do not connect the 'USB' cable from the scanner to your PC before installing the 'drivers' or the 'scanning application / software'. Digital Check does not provide scanning software. Please contact your bank or other solution provider for further assistance with installing the driver or getting the scanning software set up or installed.

Digital Check provides only an optional driver installation utility and a separate demonstration program.

Step 1: Download or Run the 'TellerScan USB Driver' installation file from www.digitalcheck.com

Step 2: If the scanner is currently connected to the PC, disconnect the 'USB' cable from the PC. Turn the power off on any locally attached USB devices, such as printers, scanners or multifunction devices. This will help eliminate any possible conflicts between the various USB devices connected to the PC during the driver installation.

Step 3: If downloaded / saved to a local drive, double-click on the TellerScanDriver.exe file to start the installation sequence. Follow the on-screen steps to complete the installation.

Step 4: With the 'USB and 'Power Supply' cables connected to the PC, the status LED on the scanner should now be active.

- ✓ Windows should now detect a new hardware device.
- ✓ The scanner is ready to be used with a 'scanning application' or a Digital Check demo program.

Installing ScanLite2

The Digital Check demo program (ScanLite2) is a basic utility that allows you to scan and view images and test the various scanner functions. 'ScanLite2' is also useful for cleaning the scanner. See the 'Cleaning the TS240 Drive Rollers' section for additional information.

Step 1: Download or Run the 'ScanLite2' installation file from www.digitalcheck.com

Step 2: If downloaded / saved to a local drive, double-click on the 'ScanLite2.exe' file to start the installation sequence. Follow the on-screen steps to complete the installation.

Step 3: 'ScanLite2' will launch automatically after installation, or it can be started from a shortcut that is placed on the Desktop during the installation process.

Note: 'ScanLite2' does not save any image or MICR data to the PC. Once the scanned item disappears from the screen or the utility is shutdown, the data is removed / cleared.

LED Status Indicator

LED Status Indicator

Off or No LED: The 'USB cable is not connected and/or no power to the scanner.



Red LED: Scanner 'USB' and 'Power Supply' cables are properly connected. This is the default state when an application is not controlling the scanner or has not yet acquired the scanner.

Note: Both ends of the 'USB' cable must be plugged in for the LED light to turn 'Red'. If the LED does not turn 'Red', check and reseat the end of the 'USB' cable going into the PC and into the scanner and that the PC is turned on. Then, check that the 'Power Supply' cables are connected properly and the source is live.



LED Status Indicator (continued)

Green LED: The scanning application has successfully acquired the scanner and it is ready to be used.



Additional LED Information: After the TellerScan TS240 is synchronized with the application; the LED is used to detect the presence of documents in the entry pocket and will turn 'Orange' when a document has been loaded.

Once the scan cycle has started, the items in the 'Entry Tray' should feed into the path one at a time. When the last has been scanned, the scanning process will stop and the items should be stacked in the 'Exit Tray'.

A flashing 'Red' LED indicates an error. Select an eject option within the application, if available, or look for a document in the path. If there is a stopped or jammed item in the path, remove it from the scanner. See the 'Accessing the TellerScan TS240' section for additional information on how to open up and access the scanner.

If the LED is still showing a 'Red' color after clearing a document jam, press and hold the 'Reset' button for 1-2 seconds to restart the scanner.

Loading Items into the Scanner

The TS240's automatic feeder can handle up to 100 items at a time. Please follow the steps below to ensure proper feeding.

Step 1: Slide out the 'Exit Tray' to expand the length of the tray to accommodate larger or business size checks. Remove all rubber bands, staples, paper clips, etc. Straighten any bent corners or excessively wrinkled documents.

Step 2: Align / jog the items to prepare them for scanning.

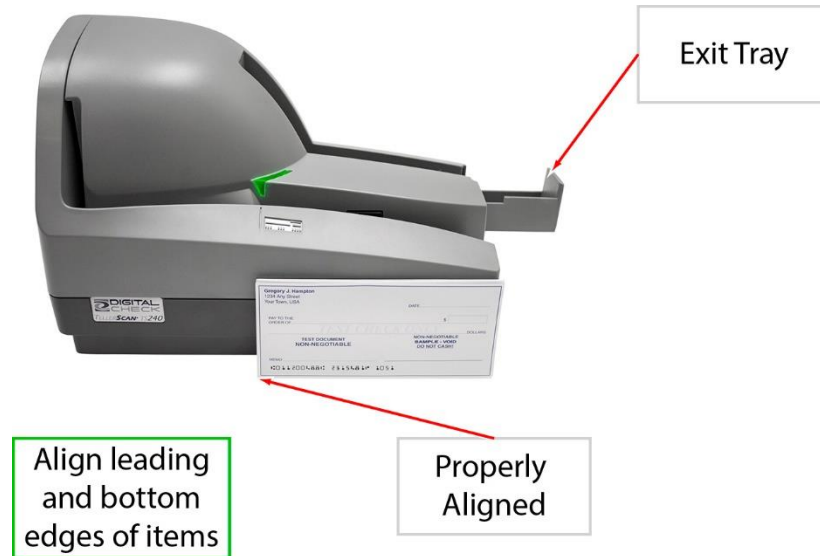

Step 3: The leading and bottom edges of items should be aligned. Place the item(s) by sliding them into the 'Entry Tray' with the front of the item facing out and away from the scanner.

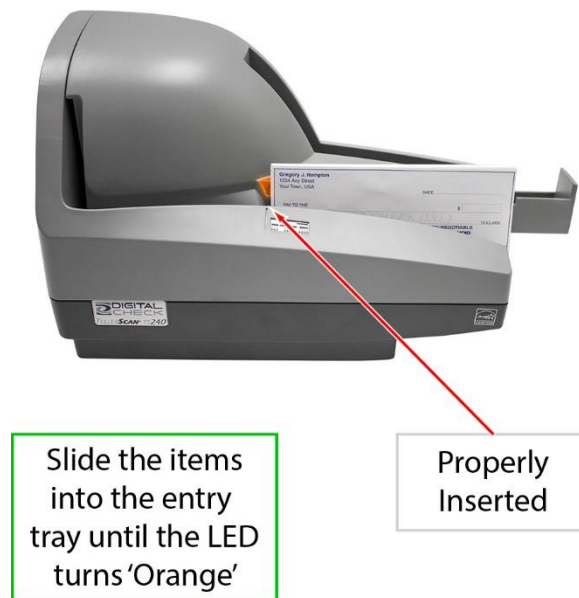

Step 4: Aligned items must be inserted flat into the 'Entry Tray' and slid forward until they stop or are pulled into the scanner.

Accessing the TellerScan TS240

Accessing the Internal Document Path

The TellerScan TS240 has two covers, the 'Center' cover and 'Outer' cover. These can be removed separately or together by lifting / pulling up on the covers.

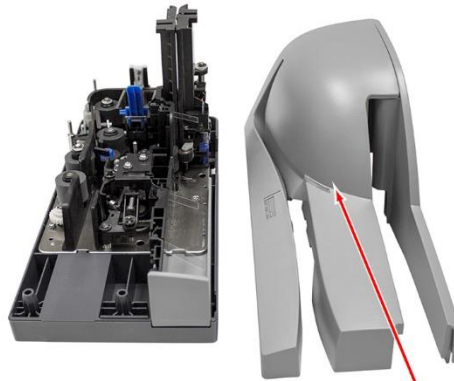

Remove the
Center and Outer
Covers

Scanner
Covers

Accessing the Cameras

Note: Older models might have a white nylon thumbscrew in place of the latch shown below.

Step 1: With the 'Center' and 'Outer' covers removed, locate the blue 'Camera Door Latch' and the tab part of the latch to unlock the camera door assembly.

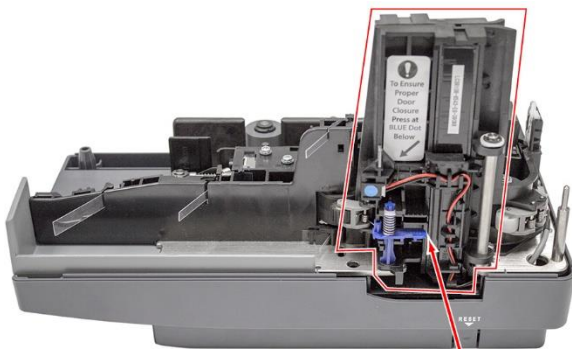

Camera
Section/Door

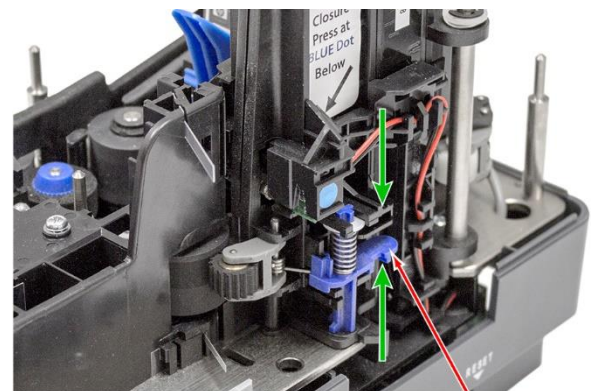

Pinch the
tab on the
Latch to open

Camera
Latch

Accessing the Cameras (continued)

Step 2: Carefully swing open the camera door once it is unlocked.

Note: Look for the white strip behind the glass, which is the camera. Be careful not to scratch the glass when cleaning or accessing the camera for any reason.

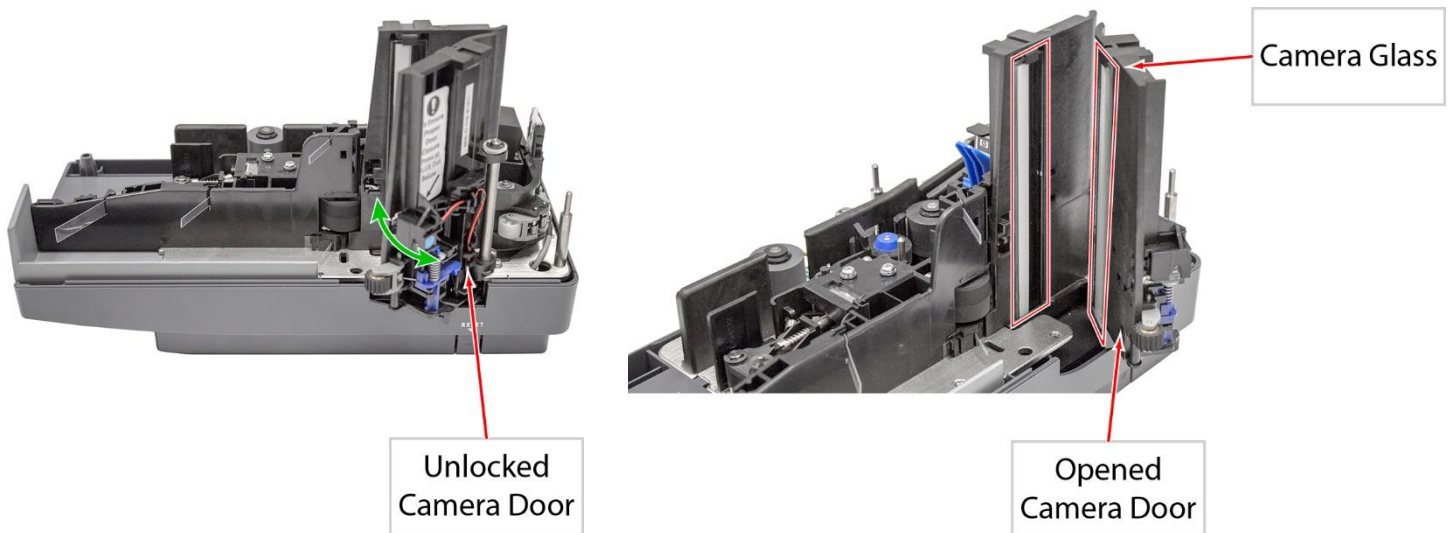

Closing the Camera Door

Note: Verify that the 'Camera Door' is locked or closed all of the way after opening or if experiencing document jams in this section of the scanner.

Step 1: Close the 'Camera Door' by swinging it back into its original position.

Step 2: Lock the 'Camera Door' by pinching the lower part of the camera assembly together. Press on the area of the door that has the blue dot. The 'Camera Door' will "click" into place and should not move or feel loose.

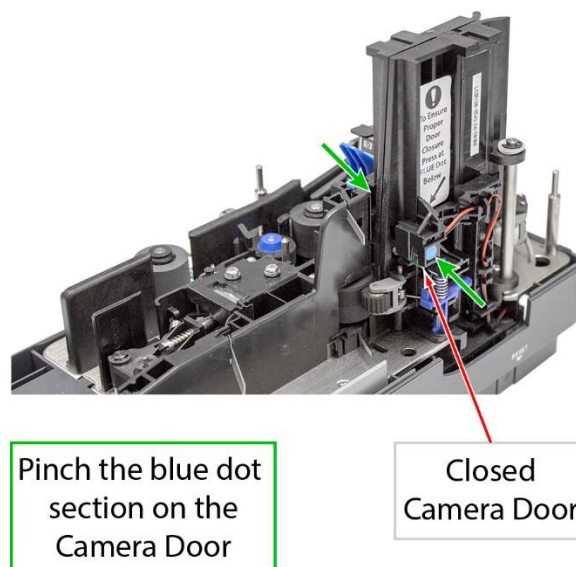

TellerScan TS240 Routine Maintenance

TellerScan TS240 Maintenance Overview

Over time, ink, dirt and dust particles will collect on the scanner rollers and in the document track. Therefore, it is necessary to clean these areas to ensure reliable performance.

Perform a periodic inspection of the document track and use a Digital Check cleaning card to clean the scanner rollers. Using a can of compressed air will help keep the document track clean.

Inspect the quality of the captured images on a regular basis. If the image quality drops off, clean the camera glass by following the procedure below.

Inspect the TS240 Document Track

In addition to routine drive roller cleaning, a periodic inspection of the entire document track area is also recommended. The use of a flashlight will enhance the visual inspection in the camera section and throughout the document track. Remove any staples, paperclips, debris etc. that might have accumulated during use.

Have a can of compressed air available to blow out the document track on a regular basis. Blow the dust toward the entry and exit pockets starting from the center of the path by the ink cartridge platform.

Cleaning the TS240 Camera

To clean the cameras, use a Digital Check cleaning swab or a clean cloth to wipe the camera glass. Be careful not to scratch the glass when cleaning or accessing the camera for any reason. See the 'Accessing the Cameras' section for additional information on opening the assembly prior to cleaning.

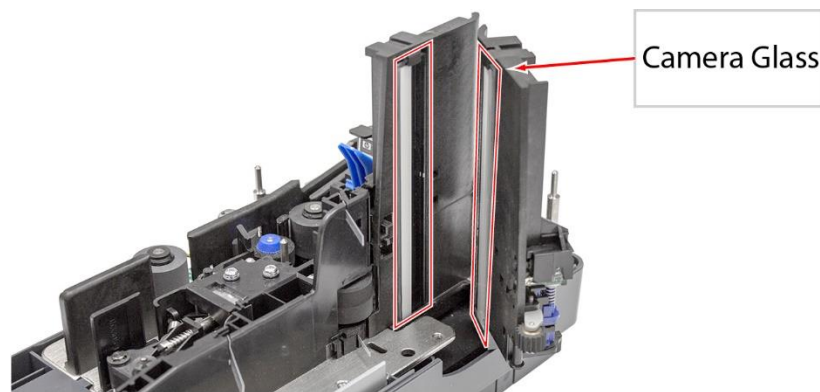

Carefully wipe the
Camera Glass

Cleaning the TS240 Drive Rollers Using a Cleaning Card

Use the Digital Check scanner cleaning swabs (PN: IS0030) and the cleaning cards (PN: IS0028 - available at www.digitalcheck.com) for regular cleaning maintenance.

Note: Use a scanning application or Digital Check's 'ScanLite2' utility to start the scanner motors so that the rollers are turning during the cleaning process.

Step 1: Insert the cleaning card into the scanner. Hold onto the card in order to "scrub" the 2 'Entry Drive' rollers. Keep holding onto the card so that it does not feed into the scanner.

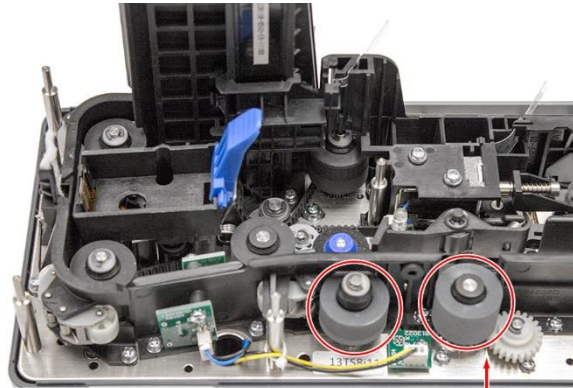

2 Entry
Drive Rollers

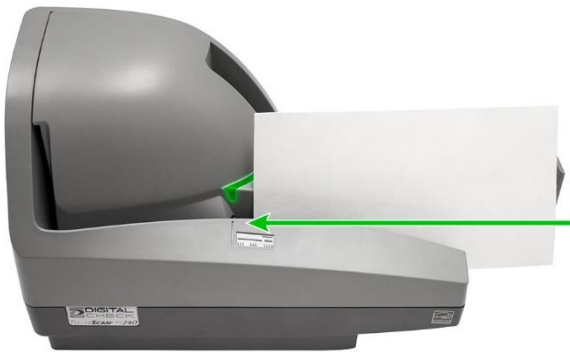

Use a cleaning
card on the Entry
Drive Rollers

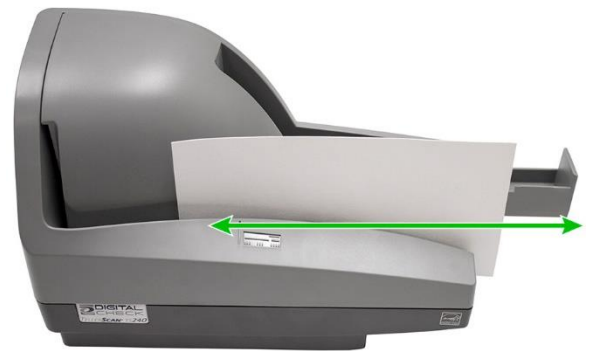

Hold onto the card
and move it back
and forth

Step 2: Feed the cleaning card through the scanner another 6-8 times. Allow the card to scan all of the way through, flipping the card between cycles, top to bottom or to a clean side after each pass through the scanner. Discard the cleaning card(s) after use.

Cleaning the TS240 Drive Rollers Using a Cleaning Swab

Note: Use the cleaning swabs for a more thorough cleaning of the scanner rollers. This can be done every few cleaning cycles.

Use the Digital Check scanner cleaning swabs (PN: IS0030) and the cleaning cards (PN: IS0028 - available at www.digitalcheck.com) for regular cleaning maintenance.

Note: Use a scanning application or Digital Check's 'ScanLite2' utility to start the scanner motors so that the rollers are turning during the cleaning process.

Step 1: Use a cleaning swab on the 2 'Entry Drive' rollers, the 4 'Main Drive' rollers and on the 'White Plastic Guide' rollers. See the '[Accessing the TellerScan TS240](#)' section for additional information on how to open up and access the scanner. Discard the cleaning swab(s) after use.

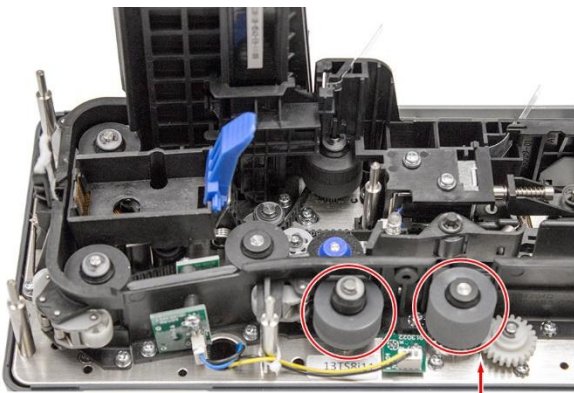

Use a cleaning swab on the Entry Drive Rollers

2 Entry Drive Rollers

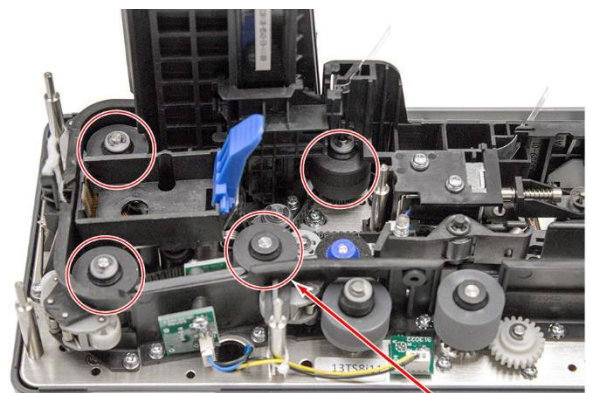

Use a cleaning swab on the Main Drive Rollers

4 Main Drive Rollers

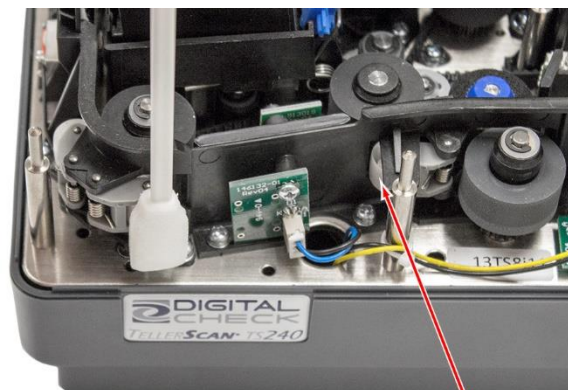

Use a cleaning swab on the White Guide Rollers

White Guide Roller

Replacing the SADR Discrimination Roller

Note: The ‘SADR Discrimination’ roller is user replaceable. Typically only needed for scanners that have been in service for longer periods of time or higher volume remote deposit or teller windows. (PN: 151161-01 - available at www.digitalcheck.com)

SADR Roller – Part Number 151161-01



Step 1: Remove the ‘Center’ and ‘Outer’ scanner covers to provide access to the ‘SADR Discrimination’ roller. See the [‘Accessing the TellerScan TS240’](#) section for additional information on how to open up and access the scanner.

Step 2: Lift or pull up on the ‘SADR Discrimination’ roller to remove. There are no tools required for removal.

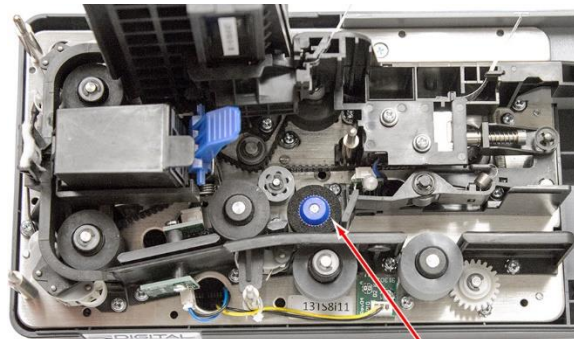

Pull up on the
SADR Roller
to remove/replace

SADR
Discriminator
Roller

Step 3: Replace the worn ‘SADR Discrimination’ roller with a new roller. The roller has a ‘D’ shape to it and will fit on the metal shaft in only one direction. Orient the roller to the correct position and push down on the roller until it comes to a stop.

TellerScan TS240 Troubleshooting

Document Feeding Problems

The TS240 features an auto-feeder and will not require any user adjustments. If you notice feeding problems, check the documents for bent or folded edges, debris in the scanner document track and that all items have been properly jogged / aligned and inserted correctly. If feeding problems are still experienced, try cleaning the drive rollers. See the 'Cleaning the TS240 Drive Rollers' section for additional information.

It might also be necessary to replace the discriminator feed roller and retest. See the service manual or contact Technical Support for additional information.

Clearing Jams

If a jam occurs, the paper path must be cleared. To do this, try to advance the jammed document by pressing the 'Eject' button on the scanner. If the document does not exit the track, grab the document with both hands and carefully wiggle the document back and forth while lifting up. See the 'Accessing the TellerScan TS240' section for additional information on how to open up and access the scanner.

Image Quality

If you notice either streaking or fading on the images, the camera glass might require cleaning. See the 'Cleaning the TS240 Cameras' section for additional information.

MICR Errors

Confirm that the document has known working MICR ink/toner. If MICR errors are still occurring, verify that the TS240 power supply or another device's power supply is at least 6 or more inches away from the scanner. Next, inspect the MICR assembly for debris, particularly metal objects. If no debris is found, inspect the assembly itself for damage or incorrect position or wiring.

Drive up teller pneumatic tubes and static build-up can also cause MICR errors, verify that the scanner is at least 6 inches away from these types of devices as well.

Using the Diagnostic Pop Up

The 'Diagnostics' will show a variety of PC and scanner information. This information can be copied and pasted into an email to send to support.

Note: To enable the diagnostic pop up the 'scanning application' has to be active and fully connected with the scanner.

Step 1: Press and hold the Shift key.

Step 2: Power cycle the scanner using the 'Reset Button' or disconnecting and then reconnecting the 'Power Supply' cable.

Step 3: Release the Shift key.

✓ The scanner diagnostics pop up should now be showing on the PC.

TellerScan TS240 Frequently Asked Questions

Is Using a Check Jogger Recommended?

Yes, to provide consistent alignment of documents, increase productivity and to reduce operator fatigue. Digital Check recommends using our MJ1000 Check Jogger (PN: 130600 – available at www.digitalcheck.com)

What is the Typical Cleaning Interval?

The recommended cleaning interval for the TS240 is approximately every 8,000-10,000 scans. Use a combination of the Digital Check Cleaning Swabs and Cleaning Cards to clean the drive rollers. See the *'Cleaning the TS240 Drive Rollers'* section for additional information.

What is the LED Status Light Sequence?

The proper LED sequence is for the LED to turn 'Red' when the 'Power Supply' and 'USB' cables are connected to the scanner and to an outlet and the PC. This is followed by the LED turning 'Green' once the application or scanning software is running and detects the scanner. If the LED does not turn 'Red', check the 'USB' and 'Power Supply' cable connection and the power source.

What About Avoiding MICR Read Head Interference?

Keep the TS240 'Power Supply' and others, small desk fans, pneumatic tubes at the teller window or similar devices at least 6-12 inches away from the scanner to keep them from interfering with the magnetic read head.

How Long Does the Ink Cartridge Last?

Once opened, the practical life of the ink cartridge is six to twelve months depending on usage and environment. However, the rated character yield on the inkjet cartridge is between 5-7 million characters. Do not shake or drop to cartridge which can cause the printing to fail. Digital Check recommends keeping a spare cartridge on hand in case the current cartridge cannot be used.

What is the Entry Tray Capacity?

The entry tray can accept up to 100 standard checks in good condition at a time.

What is the Exit Pocket(s) Capacity?

Up to 100 standard checks in good condition at a time can be stacked in either of the exit pockets.

How Many Checks Per Minute Should My TS240 Scan?

The TS240 has a rated throughput speed of up to 50, 75, 100 or 150 documents per minute (DPM) depending on the specific model (TS240-50, TS240-75, TS240-100, TS240-150). Actual throughput will vary depending on the PC configuration, physical size of the items scanned, simple or complex endorsement and the speed of the application.

TellerScan TS240 Specifications

Unit Size:

Height: 7.50" (19.05 cm)
Width: 5.10" (12.95 cm)
Length: 11.10" (28.19 cm)
Weight: 5.20 lbs. (2.40 kg)

Paper Size:

Document Height: 2.12" - 4.25" (54 - 108 mm)
Image Capture Height: Up to 4.17" (106 mm)
Document Length: 3.19" - 8.98" (81 - 228 mm)

Document Weight:

16 - 28 lb. bond (60 - 105 gsm)

Document Thickness:

0.0032" - 0.0058" (0.081 - 0.147 mm)

Document Capacity:

Entry Pocket (Check Feeder): Up to 100 items
Exit Pocket: Up to 100 items

(Optional) Printer: Programmable, single line or four line inkjet printer with user replaceable cartridge

(Optional) Franker: User replaceable red ink stamp

In-Line MICR Recognition:

(Magnetic Ink Character Recognition) for E13B (North America) and CMC7 (Europe)
Optical Character Recognition to enhance MICR Read, further enhanced using DCC's Best Read™ API function

Transport Speed: 19.69 inches per second (50 cm), 28.54 inches per second (72.5 cm) - 150 dpm

Throughput:

TS240-50 / 50 documents per minute
TS240-75 / 75 documents per minute
TS240-100 / 100 documents per minute
TS240-150 / 150 documents per minute

Standard Interface: Standard USB 2.0,

Scan Modes: Batch Capture Mode and Single Item Hand Drop Mode

Scanning Method: Concurrent Two-Sided Duplex (2 Scan Modules)

Scan Module: Contact Image Sensor (CIS)
Resolution: 300 dpi (850 Pixel Linear Array)
Light Source: Tri-Color LEDs
(Optional Front Ultraviolet Camera)

Image Resolution Optical:

300 x 300 dpi - 8 bit grayscale
300 x 300 dpi - 24 bit color

Image Resolution by Software Scaling:

240 x 240 (Scan at 300 dpi and scaling down to 240)
200 x 200 (Scan at 300 dpi and scaling down to 200)
120 x 120 (Scan at 300 dpi and scaling down to 120)
100 x 100 (Scan at 300 dpi and scaling down to 100)

Supported Compression:

JPEG (24 bit color, 8 bit grayscale)
BMP (24 bit color, 4 or 8 bit grayscale)
TIFF Group 4 B/W

DCC API Requirements:

DCC API 11.02 or newer for Energy Star models
DCC API 10.05 or newer for standard models

Supported Operating Systems:

Windows® XP, Windows Vista® (32 / 64 bit),
Windows 7® (32 / 64 bit), Windows 8® (32 / 64 bit),
Mac OS X® (10.6 or newer)
Ubuntu® 7.05 (or newer), Red Hat AS, OpenSuse

Electrical: Power consumption: 45 Watts

Input Voltage: 100 to 240 VAC, 50/60 Hz

Separate Standard Power Supply: Auto sensing for voltage

Product Warranty: 1 year or 4 million item scans

Mean Time To Repair (MTTR): 15 minutes

Environmental:

Operating Temperature: 60° - 90° F (15° - 32° C)
Operating Humidity: 35 - 85% non-condensing

Certifications:

Safety: UL, cUL, CE
FCC: Class A
EMC: IEC CE
Efficiency: CEC V 115V - Power Supply
RoHS Compliant

Digital Check Contact Information

Digital Check Corp.

Corporate Headquarters

Digital Check Corp.
630 Dundee Road
Suite 210
Northbrook, IL 60062
Phone: (847) 446-2286
Fax: (847) 441-5507

Manufacturing Facility

Digital Check Corp.
10231-A Trademark Street
Rancho Cucamonga, CA 91730
Phone: (909) 945-5106
Fax: (909) 948-3788

Visit us at
www.digitalcheck.com

- ✓ Purchase Consumables
- ✓ Additional Product Information
- ✓ Technical Support and More



TellerScan is a trademark of Digital Check Corp.
All other trademarks are the property of their respective owners.